

Vertical pillow-type packaging machine for powder and granules

MC501/MC601

MC501



MC501 is a vertical pillow-type packaging machine for small quantity of material. It is suitable for packaging roasted small pieces of rice cake, roasted peanuts, and so on, as well as powder and granules. A tetrapack packaging machine is available. Since a microcomputer is built in, setting the pitch is easy and the data for various kinds of products can be store in memory. Therefore, the operability is excellent.

Packaging style (Dimensions)

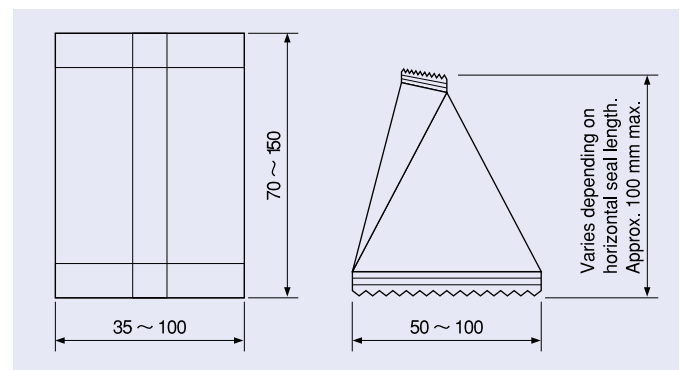

MC601 is a vertical pillow-type packaging machine for large quantity of material. It is possible to package fine powder such as soybean flour as well as powder and granule by connecting an auger filling device to this machine.

Weighing and packaging roasted peanuts are possible by connecting a quantity measuring device or counter. Since a microcomputer is built in, setting the pitch is easy and the data for various kinds of product can be store in memory. Therefore, the operability is excellent.

MC601

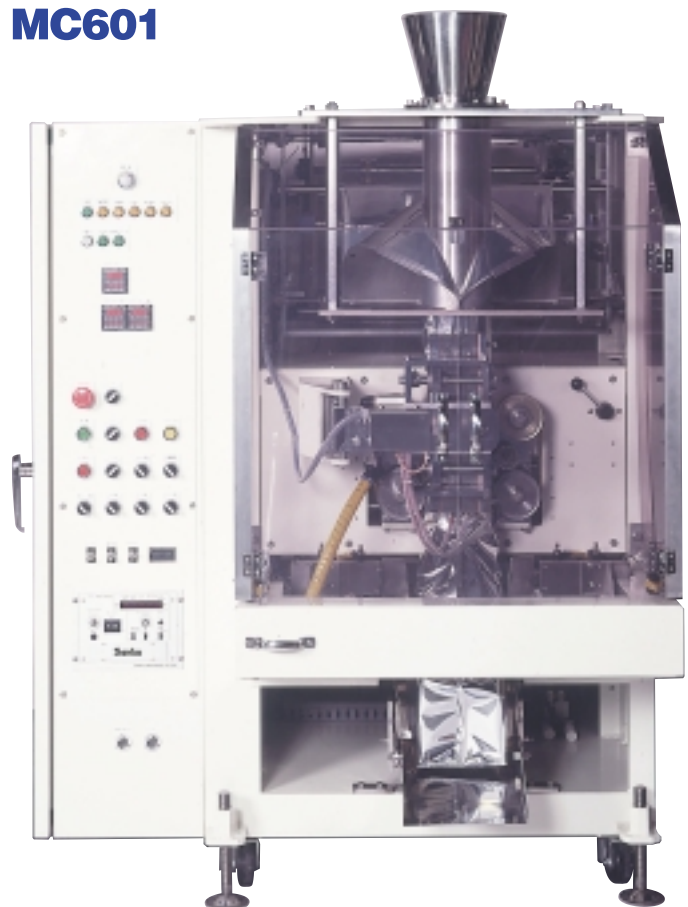

Packaging style (Dimensions)

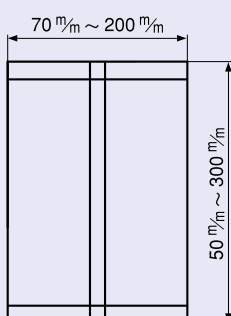

Optional devices of MC501 and MC601



●Screw conveyor

Supply and transport can be done automatically by attaching a leveler to the hopper and connecting a screw conveyor.

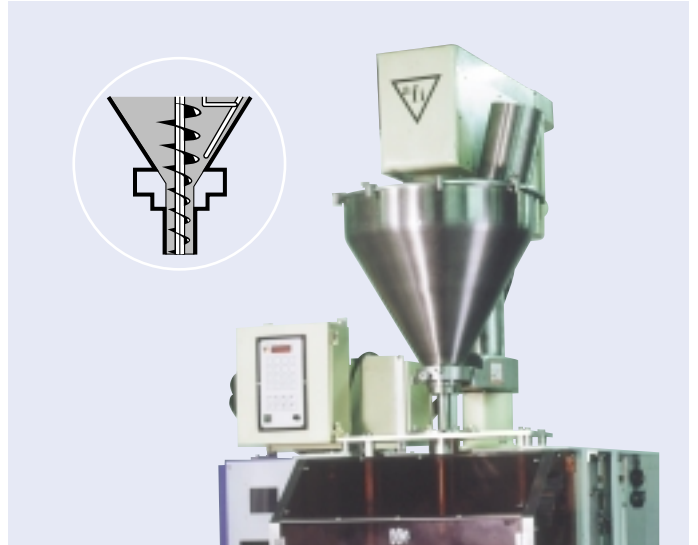

●Auger filler

The volume can be set by setting the number of revolution of the auger. It is suitable for filling fine powder.

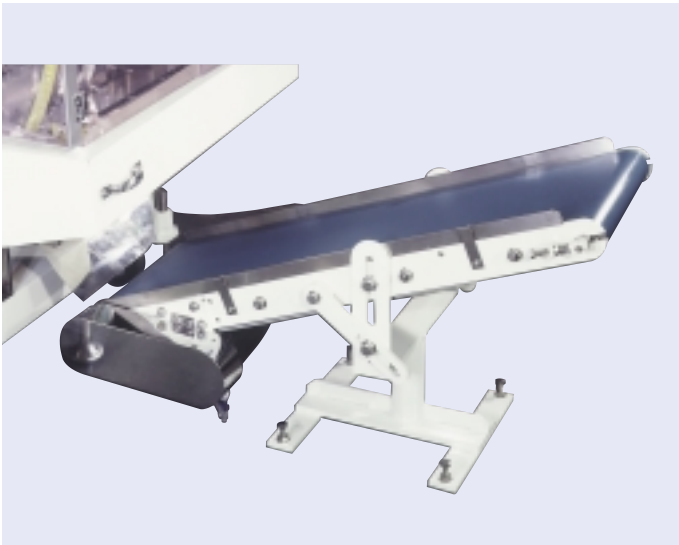

●Product carry-out conveyor

The most suitable dimensions (belt width, belt length, and speed) will be determined through discussion with the user.

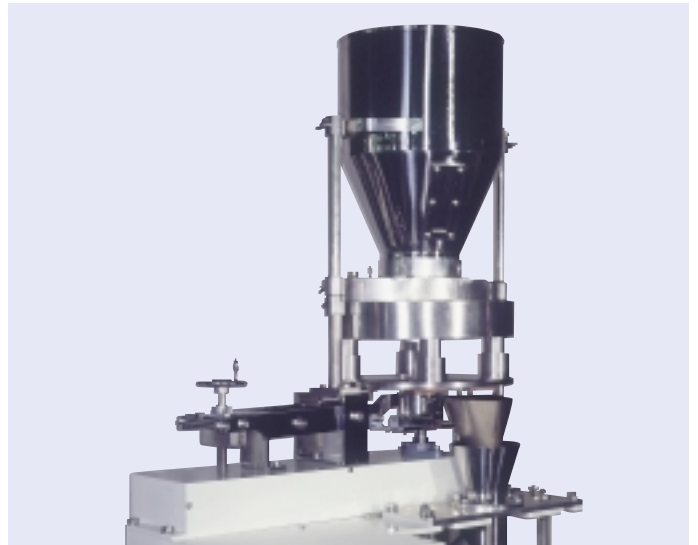

●Variable volume turn-table filling device

This device is suitable for filling of granules of good fluidity. The filling volume can be adjusted as desired by turning the handwheel.



Specifications

MC101 / MC303

Model	MC101	MC303
Packaging style	3-side sealing	3-side sealing
Bag length	30 to 125 mm	50 to 195 mm
Bag width	30 to 100 mm (*1)	50 to 150 mm
Packaging speed (*2)	60 to 120 bags/min.	30 to 60 bags/min.
Packing volume	60 cc max.	200 cc max.
Standard devices	<ul style="list-style-type: none"> ●Main body stainless steel cover ●Microcomputer controlled bag length changing device ●Photocell type pattern matching device ●Product counter ●4 heater controller ●Straight type rotary cutting device ●Heater abnormal temperature detector ●Film end stop device ●Product carry-out conveyor - 600 mm 	<ul style="list-style-type: none"> ●Main body stainless steel cover ●Microcomputer controlled bag length changing device ●Photocell type pattern matching device ●Product counter ●4 heater controller ●Straight type rotary cutting device ●Heater abnormal temperature detector ●Film end stop device ●Variable volume type rotary disk filling device ●Product carry-out conveyor - 1000 mm
Options	<ul style="list-style-type: none"> ●Variable volume type turn-table filling device ●Film joint detector ●Hot printer ●Hopper leveller ●Seal part cooling device ●Perforation device ●Chute knocker ●Chute vibrator ●Turn-table knocker ●Static electricity eliminator ●Preset number shutter ●Preset number stop device ●Empty bag detector ●Nitrogen gas flashing device ●Jammed bag detector 	<ul style="list-style-type: none"> ●Film joint detector ●Hot printer ●Hopper leveller ●Seal part cooling device ●Perforation device ●Chute knocker ●Chute vibrator ●Turn-table knocker ●Static electricity eliminator ●Preset number shutter ●Preset number stop device ●Empty bag detector ●Nitrogen gas flashing device ●Jammed bag detector
Power source	3-phase, 200 VAC	3-phase, 200 VAC
Power consumption (*3)	1.2 kW at peak, 1.0 kW on the average	1.5 kW at peak, 1.2 kW on the average
Dimensions (*3)	830 wide × 730 length × 1,725 high mm	900 wide × 900 length × 1,900 high mm
Weight (*3)	Approx. 300 kg	Approx. 500 kg

* 1: Approx. 100 mm max. It varies depending on horizontal seal width. * 2: The range will be determined through discussion with the user. * 3: Varies depending on the specifications.

MC501 / MC601

Model	MC501-P(T)	MC601
Packaging style	Pillow type package (Tetrapack)	Pillow type package (Fine seal)
Bag length	70 to 150 mm (50 to 100 mm)	100 to 350 mm
Bag width	35 to 100 mm (*1)	70 to 200 mm
Packaging speed (*2)	20 to 100 bags/min. (10 to 60 bags/min.)	10 to 100 bags/min.
Packing volume	100 cc max.	10 to 1,800 cc
Standard devices	<ul style="list-style-type: none"> ●Main body stainless steel cover ●Microcomputer controlled bag length changing device ●Photocell type pattern matching device ●Product counter ●3 (5) heater controller ●Air cylinder type cutting device ●Heater abnormal temperature detector ●Film end stop device ●Variable volume type turn-table filling device ●Low air pressure alarm 	<ul style="list-style-type: none"> ●Microcomputer controlled bag length changing device ●Photocell type pattern matching device ●Product counter ●4 heater controller ●Air cylinder type cutting device ●Heater abnormal temperature detector ●Film end stop device ●Low air pressure alarm
Options	<ul style="list-style-type: none"> ●Punching device (with tag) ●Film joint detector ●Hot printer ●Hopper leveller ●Seal part cooling device ●Chute knocker ●Turn-table knocker ●Static electricity eliminator ●Preset number shutter ●Preset number stop device ●Nitrogen gas flashing device ●Independently driven product carry-out conveyor 	<ul style="list-style-type: none"> ●Film joint detector ●Turn-table filling device (Measuring cup type) ●Auger filler ●Measuring device ●Hot printer ●Hopper leveller ●Seal part cooling device ●Static electricity eliminator ●Preset number stop device ●Dust collector ●Nitrogen gas flashing device ●Independently driven product carry-out conveyor
Power source	3-phase, 200 VAC	3-phase, 200 VAC
Power consumption (*3)	1.5 kW (2.5 kW) at peak, 1.0 kW (2.0 kW) on the average	3.7 kW at peak, 3.0 kW on the average
Dimensions (*3)	900 wide × 870 length × 1,850 high mm	1,500 wide × 1,400 length × 1,500 high mm
Air consumption	0.59 MPa, 100 NL (120 NL)	0.50 MPa, 300 NL
Weight (*3)	Approx. 450 kg	Approx. 700 kg

* 1: Approx. 100 mm max. It varies depending on horizontal seal width. * 2: The range will be determined through discussion with the user. * 3: Varies depending on the specifications.

US-10

Model	US-10	
Packaging style	3-side sealing	Tetrapack
Bag length	40 to 100 mm	50 to 80 mm (Length of the side)
Bag width	50 to 80 mm	50 to 80 mm (Length of the side)
Packaging speed (*1)	10 to 60 bags/min.	10 to 50 bags/min.
Packing volume	60 cc max.	
Standard devices	<ul style="list-style-type: none"> ●Main body stainless steel cover ●Microcomputer controlled bag length changing device ●Photocell type pattern matching device ●Product counter ●Film end stop device ●Variable volume type turn-table filling device ●Ultrasonic sealing device ●Low air pressure alarm ●Static electricity eliminator 	
Options	<ul style="list-style-type: none"> ●Chute knocker ●Turn-table knocker ●Preset number shutter ●Preset number stop device ●Independently driven product carry-out net conveyor 	
Power source	3-phase, 200 VAC	
Power consumption (*2)	1.2 kW at peak, 1.0 kW on the average	
Dimensions (*2)	800 wide × 900 length × 1,850 high mm	
Weight (*2)	Approx. 400 kg	

* 1: The range will be determined through discussion with the user. * 2: Varies depending on the specifications.